

Bell 407
Heliport Design Data and Dimensions

407
 STD GEAR

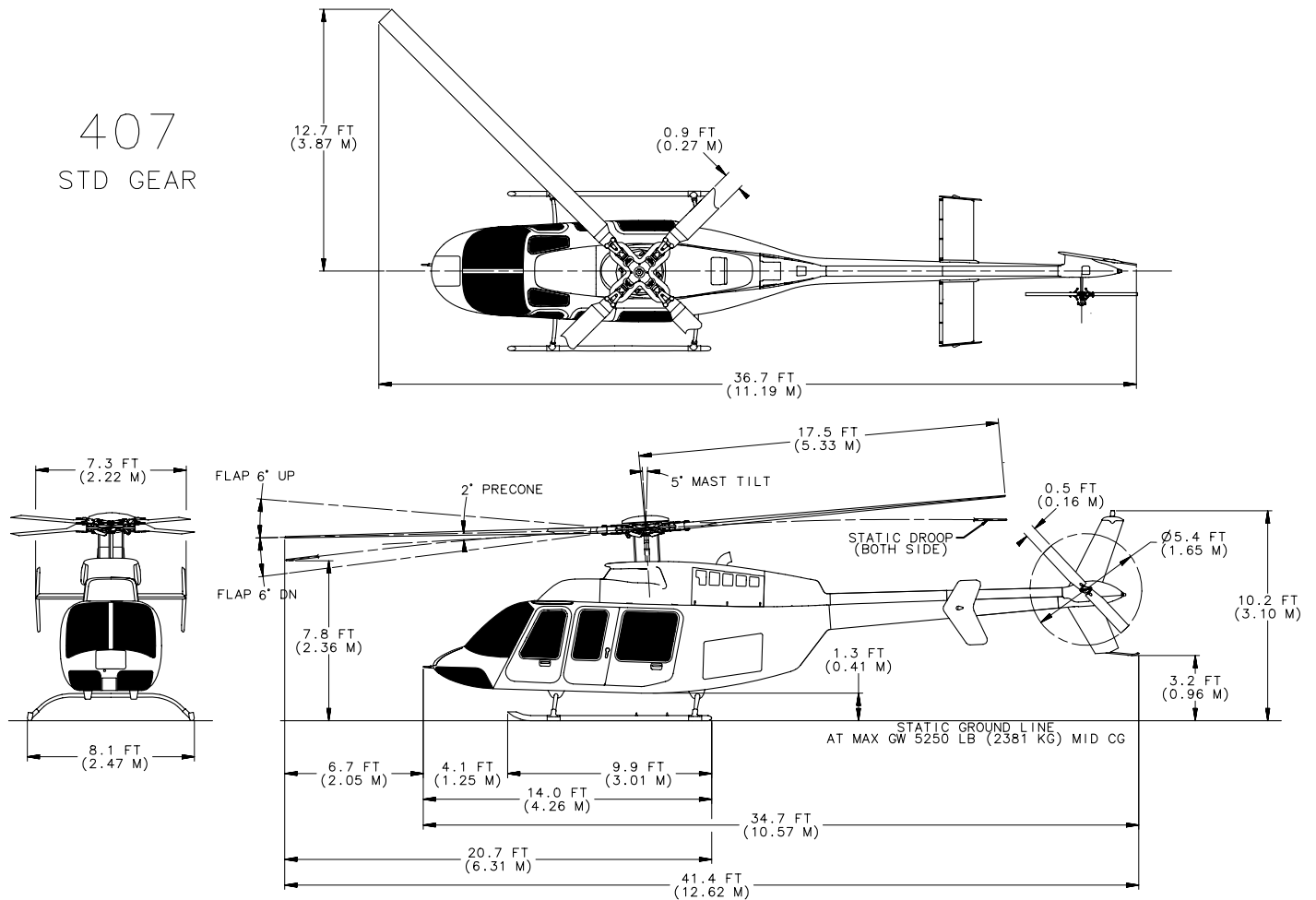

LANDING GEAR LOADING AT MAXIMUM GROSS WEIGHT (5250-POUNDS),
 BASED ON 1G STATIC CONDITIONS AT AFT-MOST STRUCTURAL CG LIMIT

Gear Type	Loading (lb)		Contact Area (in ²)		Contract Pressure (lb/in ²)	
	Forward	Aft	Forward	Aft	Forward	Aft
Standard Skid	1405	3845	16.5 x 2.0	16.5 x 2.0	43	117
High Skid	1372	3878	16.5 x 2.0	16.5 x 2.0	42	118
Emergency Floats	1372	3878	16.5 x 2.0	16.5 x 2.0	42	118