

# Bell 430 (Wheel Landing Gear) Heliport Design Data and Dimensions

430  
WHEEL GEAR

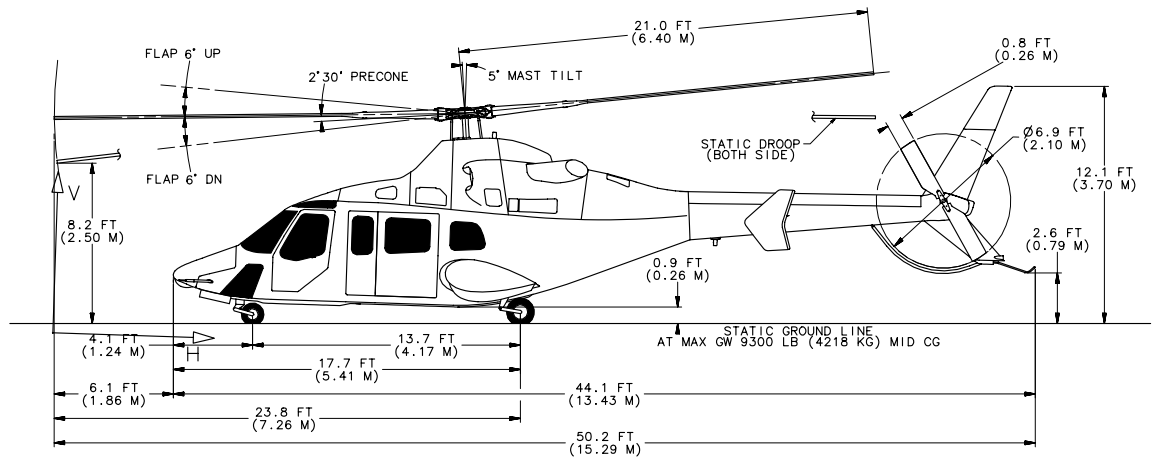
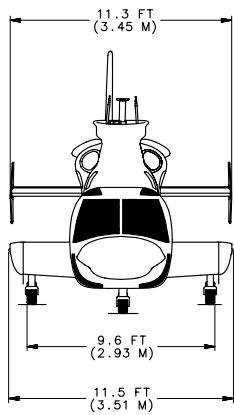
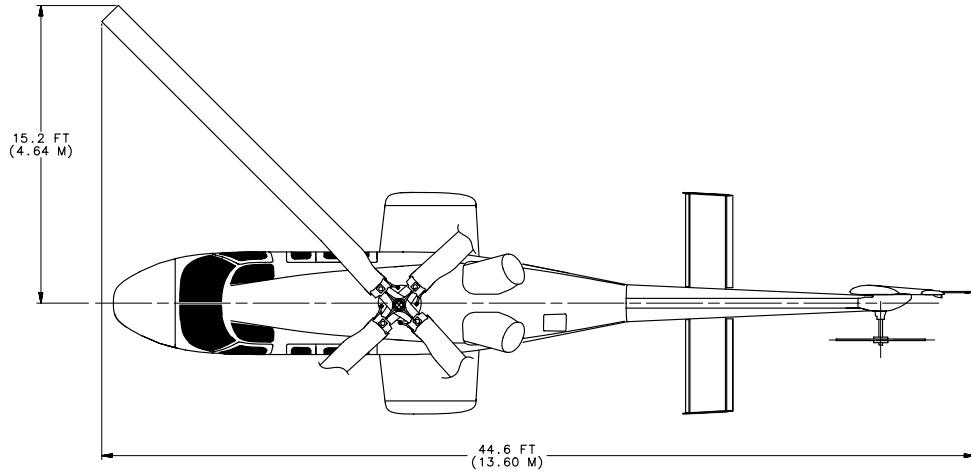

LANDING GEAR LOADING AT MAXIMUM GROSS WEIGHT (9300-POUNDS),  
BASED ON 1G STATIC CONDITIONS AT AFT-MOST STRUCTURAL CG LIMIT

Loading Condition	Loading (lb)		Contact Area (in <sup>2</sup> )		Contract Pressure (lb/in <sup>2</sup> )	
	Forward	Aft	Forward	Aft	Forward	Aft
Max Gross Weight	1624	7676	18.85	31.8 x 2.0	86	121
1.5 x MGW	2437	11,513	25.1	43.8 x 2.0	97	131